

Manual

# EQF 3320

Particle size specific Radon/Thoron gas and progeny monitor

Version 02/2026

Reference documents:

Software manual dVISION

SARAD GmbH

Wiesbadener Straße 10

01159 Dresden

[www.sarad.de](http://www.sarad.de)

[info@sarad.de](mailto:info@sarad.de)



## Content

Operational controls.....	5
Basic unit .....	5
Sampling head for Radon/Thoron progeny.....	6
1. Overview.....	7
1. 1. The DACM32 platform as basic radon monitor .....	7
1. 2. Control of the measurement process- measuring cycles .....	7
1. 3. Alarm-system.....	7
1. 4. Event -memory .....	8
1.5. Communication with the host-system .....	8
2. Operation .....	9
2. 1. Switching ON/OFF, standby-mode, fuse .....	9
2. 2. Power supply .....	9
2. 3. Operation panel (Touchscreen).....	9
2. 4. Interfaces.....	10
2. 4. 1. Interfaces for communication (COM1, COM2).....	10
2. 4. 2. Analog output .....	10
2. 4. 3. Sockets for external accessories (AUX1, AUX2).....	11
2. 5. Data storage of measurements .....	11
2. 6. Menu navigation.....	11
2. 6. 1. Main page .....	11
2. 6. 2. Display of module information and module settings .....	12
2. 6. 3. Display of component configuration .....	14
2. 6. 4. Selection of measurement cycle .....	14
2. 6. 5. Display of actual measured values .....	15
2. 6. 6. Display of the stored measurement values.....	15
2. 6. 7. Graphical display of the measurement data as a time series .....	16
2. 6. 8. Display of basic data .....	17
2. 6. 9. Alarm-display .....	19
2. 6. 10. Display of event memory.....	19
2. 7. Setup (timer, synchronous start, display switch off).....	20
2. 7. 1. Timer.....	20
2. 7. 2. Synchronous start at a set time of day.....	20
2. 7. 3. Display shutdown interval .....	20
2. 8. The integrated GPS receiver .....	21

---

3. Sensors and actuators in the EQF 3320.....	22
3. 1. Radon gas measurement, temperature and relative humidity.....	22
3. 1. 1. Measuring principle .....	22
3. 1. 2. DACM32-components for the radon measurement .....	23
3. 1. 3. Display of measuring values for radon, temperature and humidity .....	23
3. 2. Particle size specific Radon progeny measurement.....	23
3. 2. 1. Functional principle .....	23
3. 2. 2. DACM32-components for radon progeny .....	24
3. 2. 3. Display of radon progeny products .....	24
3. 3. Flow measurement, flow control and pump current.....	25
3. 3. 1. Functional principle .....	25
3. 3. 2. DACM32-components for internal air circuit .....	25
3. 3. 3. Display of the measured values of the air circuit .....	25
3. 4. Barometric pressure, differential pressure (option) .....	25
3. 5. Warning and alarm lights .....	26
3. 6. The connectors „AUX1“ and „AUX2“ .....	26
4. EQF 3320 monitor configuration.....	28
4. 1. Predefined measuring cycles.....	28
4. 2. Predefined warnings and alarms.....	28
5. Important hints on operating the monitor.....	30
5. 1. Vibrations and strong electromagnetic fields .....	30
5. 2. Aggressive Gases .....	30
5. 3. Environmental conditions .....	30
5. 4. Check up of the alpha spectra .....	30
5. 5. Avoiding condensation .....	30
5. 6. Water inlet protection.....	30
5. 7. Filter at the air inlet of the monitor .....	31
5. 8. Rechargeable battery .....	31
5. 9. Hints for the sampling head for progeny .....	31
5. 9. 1. Connection and placing .....	31
5. 9. 2. Replacing the filter.....	32
5. 9. 3. Screen cleaning and replacement .....	32
5. 9. 4. Limitations of the sampling head .....	32
6. Use of accessories .....	33
6. 1. Accessory adapter .....	33
6. 2. Case for harsh environmental conditions .....	33

---

6. 3. Light tower.....	33
6. 4. Gamma dose rate probe.....	33
6. 5. Soil gas probe .....	34
6. 5. 1. Hints for soil gas measurements .....	34
6. 5. 3. Connection of soil gas probe .....	34
6. 5. 4. Use of the simple soil gas probe.....	34
6. 6. Aqua-Kit for determination of radon concentration in water samples.....	34
6. 6. 1. Measuring principle and accessory .....	34
6. 6. 2. Precautions against condensation and water ingress .....	35
6. 6. 3. Carrying out the measurement .....	35
6. 6. 4. Measuring cycle and used components .....	36
6. 7. External temperature and humidity sensor .....	36
Attachment.....	37
A) DACM32 components .....	37
A1 – Type of components of DACM32 .....	37
A2 – Overview of the used components in EQF 3320.....	37
B) Connector pin assignment .....	38
C) Disposal instructions .....	39

## Operational controls

### Basic unit

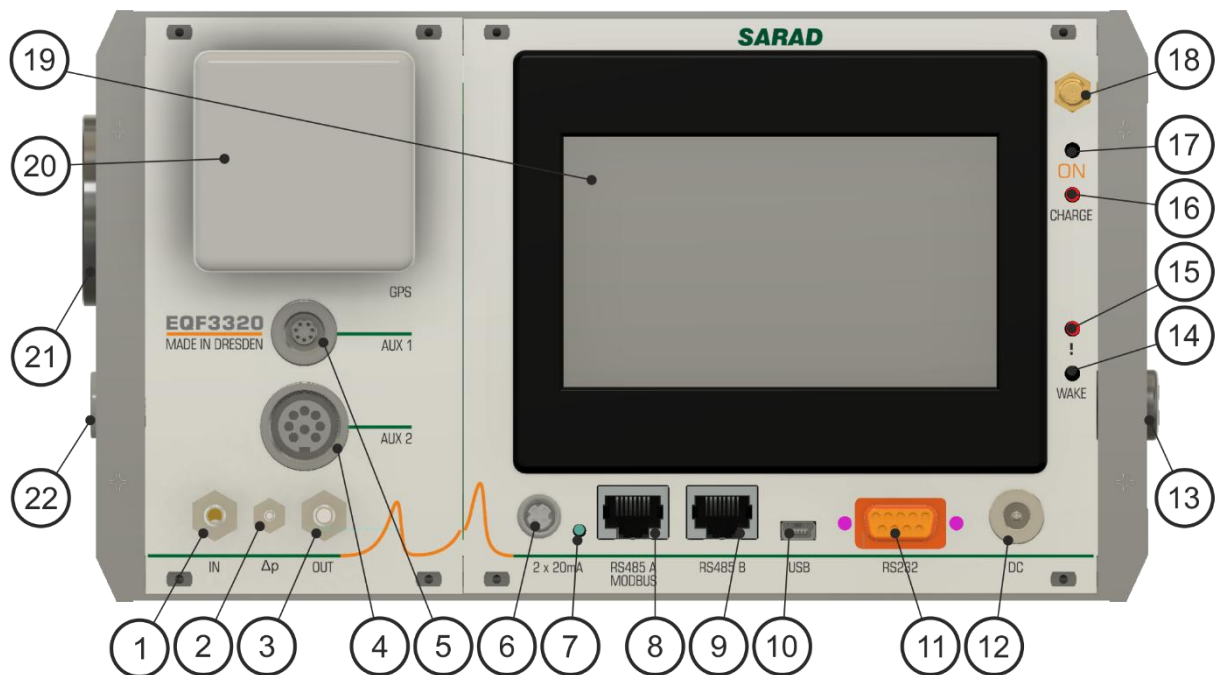
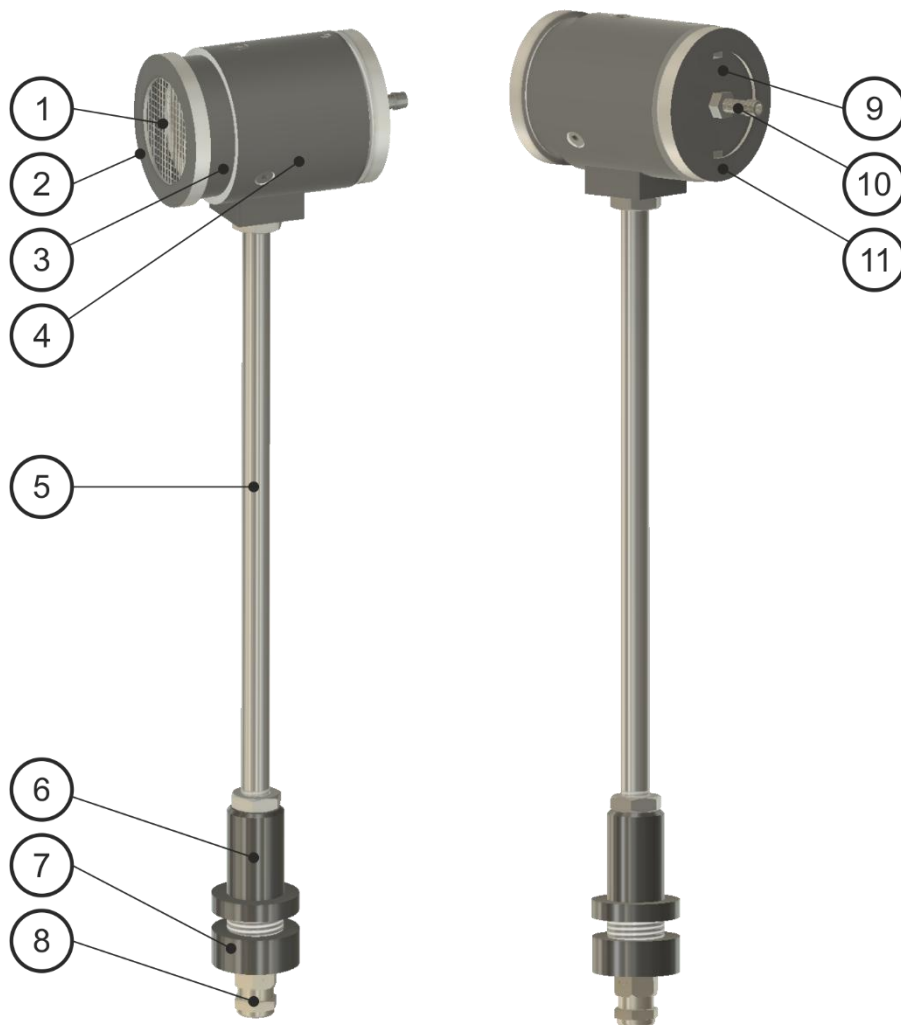

fig 1: basic unit

- 1) Internal air circuit air inlet
- 2) Connection for differential pressure measurement
- 3) Internal air circuit air outlet
- 4) Accessory socket "AUX2" for connecting signal lights
- 5) Accessory socket "AUX1" for connecting the radon progeny measurement head
- 6) Connection socket for 2x 0-20 mA current loop outputs
- 7) LED indicator for activated current loop outputs
- 8) RS485A interface (configurable for MODBUS RTU protocol)
- 9) RS485B interface
- 10) USB Type B Mini interface
- 11) RS232 interface
- 12) Connection socket for power supply
- 13) Fuse
- 14) Button for activating the display
- 15) LED indicator for alarms / warnings
- 16) LED indicator for charging status
- 17) Power ON - button
- 18) WIFI antenna socket (option)
- 19) Coloured touchscreen display
- 20) GPS receiver
- 21) Accessory adapter (RP-head, water intake protection (optional))
- 22) Connection socket for water ingress protection (optional)

## Sampling head for Radon/Thoron progeny



*fig 2: Sampling head for unattached and attached Radon progeny*

- 1) Screen for deposition of unattached progeny
- 2) Union nut for screen
- 3) Screen support
- 4) Tube
- 5) Stand
- 6) Mounting socket with thread M16x1
- 7) Knurled nut
- 8) Cable gland for connection cable to basic unit
- 9) Pressure plate for filter
- 10) Hose connector for connecting air hose to air inlet of the basic unit
- 11) Union nut for pressure plate

---

## 1. Overview

### 1.1. The DACM32 platform as basic radon monitor

The monitor is based on the DACM32 measurement platform developed by SARAD. This platform is based on a microcontroller with proprietary firmware. Since no operating system is used and communication also takes place via proprietary protocols, maximum protection against tampering is guaranteed.

The DACM32 platform is based on hardware with a number of universal interfaces to which a wide variety of sensors and actuators can be connected. Simple examples are an analogous input and a switching output. These interfaces are referred to as components in the DACM32, and the different types of interfaces are referred to as component types. Each component can be parameterized using configuration software to calculate the respective measured values in the desired physical unit from the sensor's electrical output signal. Each component is uniquely indexed in the DACM32 and has a unique name. This consists of an abbreviation for the component type followed by an index if multiple components of a type are present (example: AIN2 refers to analogous input no. 2). Each component is assigned an alias name via configuration that identifies the component in a user-friendly manner. Depending on requirements, the short names or alias names are used on the monitor display, in the configuration software, and in the operating software. The appendix contains a list of all component types with a brief functional description.

A specific measuring monitor is created by combining the DACM32 hardware with the required sensors and actuators, as well as the associated component and monitor configuration. Standard users do not need to worry about these aspects, as the monitors are fully configured for the respective measurement task upon delivery. However, familiarity with the platform concept will help you better understand this manual. Furthermore, both monitor manufacturers and experienced users can implement customized modifications quickly and easily.

### 1.2. Control of the measurement process- measuring cycles

A measurement cycle defines the time interval at the end of which the measured values acquired during this interval are stored in the data memory. Depending on the definition, the measurement cycle is repeated for a defined number of measurements or indefinitely, so that the measurement data is available as a time series. Up to 15 measurement cycles can be stored in the monitor, customized for the respective measurement task. The required measurement cycles for all standard applications are already included upon delivery. The measurement cycles are defined using configuration software, allowing experienced users to create their own cycles.

Within a measurement cycle, each component can be controlled individually. It is defined which components are included in a measurement – and when within a cycle a component should generate data or activate actuators.

### 1.3. Alarm-system

A maximum of 32 independent alarms can be freely defined. Any measurement value available in the monitor can be used as the data source for an alarm. A distinction is made between alarms for current sample values (measurement and verification every second) and interval alarms (verification of the integral values at the end of the interval). An alarm is acknowledged either via the touch panel, a communication interface, or (if provided in the monitor) via an input for connecting a button. The types of acknowledgements permitted can be determined via configuration. An on and off threshold can be defined for each alarm, allowing the implementation of a hysteresis. If the on threshold is

greater than the off threshold, an alarm is generated when the measured value increases; otherwise, an alarm is generated when the measured value decreases. Each alarm can be assigned several actions that are executed by the corresponding components (e.g., activating a signal light via a switching output). The alarm settings configured in the monitor are described in the "Predefined Warnings and Alarms" section.

#### **1.4. Event -memory**

The last 100 important events affecting the monitor are stored in the event log with a time stamp. This log cannot be deleted by the user, so errors, alarm situations, and tampering with the monitor can be traced later. The following events are recorded:

- Turning the monitor on and off
- Setting the monitor clock
- Changes to the component or monitor configuration
- Selecting a measurement cycle
- Starting and stopping the measurement
- Occurred alarms
- Confirmation of alarms

#### **1.5. Communication with the host-system**

All monitor settings, data transfer, and remote control of the monitor are performed independently of the communication channel using a proprietary protocol. This protocol is used by all SARAD software solutions. Additionally, current measurement data can be retrieved via the industry-standard "MODBUS RTU" protocol. Separate applications are available for monitor configuration (dCONFIG) and monitor operation (dVISION).

---

## 2. Operation

### 2.1. Switching ON/OFF, standby-mode, fuse

For safety reasons, the monitor is shipped with the removed fuse. Before switching the monitor on, please open the fuse holder on the right side of the housing, insert the fuse, and then close the fuse holder again. Press the "ON" power button and hold it for a few seconds until the SARAD logo appears on the display. The monitor is switched off using the "OFF" touch button in the main menu (top centred).

After completing a measurement, the monitor goes into "standby" mode so that the monitor is not completely disconnected from the internal battery. The display is deactivated after a configurable time interval. The display is activated by pressing the "WAKE" button.

If the monitor is not used for an extended period of time, the battery should be fully charged and disconnected from the power supply by switching it off using the "OFF" touch button in the main menu on the display. The fuse must be removed for shipping or air transport.

### 2.2. Power supply

The monitor contains a NiMH battery with a nominal voltage of 12 V and a capacity of 7.6 Ah. Power consumption during measurement depends on the monitor configuration and the components/sensors used in the measurement cycle. To maximize battery operating time, use only the components/sensors actually required.

The battery is charged using the included plug-in power adapter (18-20 V/60 VA). The integrated charging circuit allows the battery to be fully charged within four hours. The "DC" connection socket for the power adapter is located at the bottom right of the front panel of the monitor. The red LED indicator to the right of the display lights up during charging. It goes out when the battery is fully charged.

The monitor can be operated continuously with the power supply. The charging control ensures cyclic charging to optimize battery life. During the charging process, heat is released, which causes the entire monitor to heat up. The integrated temperature sensor then displays significantly elevated values. To accurately measure the outside temperature, an additional sensor separate from the monitor should be used in the case of continuous mains operation.

If the battery voltage drops below 11.2 V during a measurement, the measurement is aborted. If the discharge continues below a threshold of 10.6 V, the deep discharge protection completely shuts down the monitor's electronics. The monitor can only be switched on again once the battery voltage has reached the threshold of 11.6 V during the charging process.

The battery should always be charged at temperatures between 10 °C and 30 °C. At ambient temperatures above 40 °C, charging is automatically interrupted to protect the battery. When not in use, the monitor should be turned off using the "OFF" touch button in the main menu.

### 2.3. Operation panel (Touchscreen)

The monitor is operated via touchscreen. The display and backlight consume a relatively high amount of power, so they automatically shut off even during a measurement if no input is made. The time from the last touch to shutdown can be set to a maximum of 255 seconds via the monitor setup.

The display is activated as soon as the black "WAKE" push button is pressed. The last displayed page is always activated afterward. All other operating functions are controlled via the dynamic touch buttons shown on the display.

## 2. 4. Interfaces

### 2. 4. 1. Interfaces for communication (COM1, COM2)

The monitor has two independent communication channels (COM1, COM2) that can be used to communicate with the monitor simultaneously. Different physical interfaces are assigned to each channel, which are automatically switched between according to a priority scheme.

The following interfaces are assigned to the COM1 communication channel:

- USB: active as soon as a USB connection is established
- RS232: active when an RS232 signal is detected and no USB connection is present
- RS485B: active when neither a USB nor an RS232 connection is present

The COM1 communication channel cannot be configured using configuration software. This ensures constant access to the monitor. The data transfer speed can be increased by pressing the "COM1" button in the main menu.

The following interfaces are assigned to the COM2 communication channel:

- WLAN: active when WLAN has been activated by the user and the monitor is logged in
- RS485A: active when the monitor is not logged in to the WLAN

The COM2 communication channel is configured using the setup functions of the configuration software. The following modes are available:

- SARAD 9600 bps no parity
- SARAD 115200 bps no parity
- MODBUS 9600 bps even parity
- MODBUS 19200 bps even parity
- SARAD wireless

The modes marked with "SARAD" use the proprietary SARAD protocol. This includes data transfer and complete monitor control.

The industry standard MODBUS RTU is also supported. This protocol only supports querying current measured values. Information on using the MODBUS RTU protocol can be found in the document "AN-009-sarad\_modbus\_rtu\_protocol".

The "SARAD wireless" setting must be selected to activate the WLAN interface. If WLAN is not used, this mode should not be selected, as operating the wireless interface consumes a relatively high amount of power. Once this mode is enabled, the monitor will only switch to the WLAN connection once it is logged in. The WLAN access data (SSID, password, server, and port) must be entered in the setup function of the configuration software.

### 2. 4. 2. Analog output

The monitor has two freely configurable current loop outputs, which are available at the "2 x 20 mA" socket. The following output signal options are available:

- 0...20 mA
- 4...20 mA
- 0...24 mA

Each output can be assigned any measured value acquired in the monitor. The desired value range of the measured value must be assigned to the selected output range (e.g., for battery voltage: 4...20 mA corresponds to 0...15 V). All settings are made using the setup function within the configuration software.

### 2. 4. 3. Sockets for external accessories (AUX1, AUX2)

The two sockets provide additional components of the DACM32. They can be used to control external accessories or integrate external sensors into the system. In addition to the standard configuration, monitor- and user-specific modifications are possible. The standard configuration is documented in the section "AUX1 and AUX2 Connectors." Customer-specific configurations are described in a separate document.

### 2. 5. Data storage of measurements

The measurement data is stored on an internal SD card. Several million data records can be stored. The generated measurement data is always saved as raw data, i.e., in the binary format generated by the components. This ensures absolute traceability of the measurement data for quality assurance purposes. A component can generate one or more measured variables from the raw data. To display the measured values on the monitor or to retrieve current measured values via the communication interface, they are calculated based on the raw data using the component configuration. When transferring the complete measurement data to the host system, however, only the compressed raw data is transferred along with the component configurations. The host system then generates the actual measurement results from this.

Please note that the monitor can collect very large amounts of measurement data, which later result in longer transmission times via the communication interfaces. Therefore, only activate the required sensors and select the length of the measurement intervals appropriate to your application.

The data of the memory card can be deleted using the corresponding function in the operating software.

### 2. 6. Menu navigation

#### 2. 6. 1. Main page

After activating the display using the button below the display, the main navigation page appears.



*fig 3: Main menu if measurement stopped*

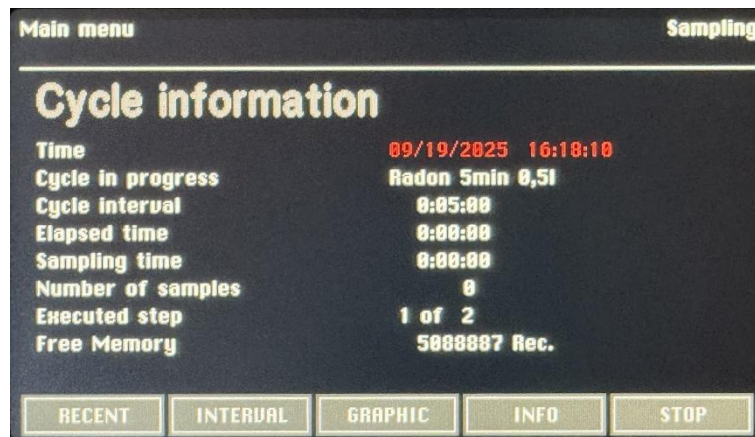

fig 4: Main menu during measurement

In "Standby" mode, the monitor name, the name of the current monitor configuration (including the date of the last change), and the selected measurement cycle are displayed. The measurement is started by touching the "START" button. While a measurement is running, the current cycle settings and system status are displayed:

- Time
- Name of the currently running measurement cycle
- Current measurement time of the current interval
- Total measurement time since the start of the measurement
- Number of the completed step and number of steps within the cycle
- Size of the free data memory (number of data records still available for storage)

From the main menu, you can also access the submenus for displaying the module and component configuration, the data stored on the memory card, and, if a measurement is running, the current measured values of the sensors.

To end a measurement in progress, touch the "STOP" button.

### 2. 6. 2. Display of module information and module settings

The display pages, accessible from the main menu via the "INFO" button, provide an overview of the module version and the current settings of various monitor parameters. The display pages can be switched using the "TOGGLE" button.

#### Page 1 Module Information

- Software Version
- Serial Number
- Manufacturing Date
- Date of Last Firmware Update

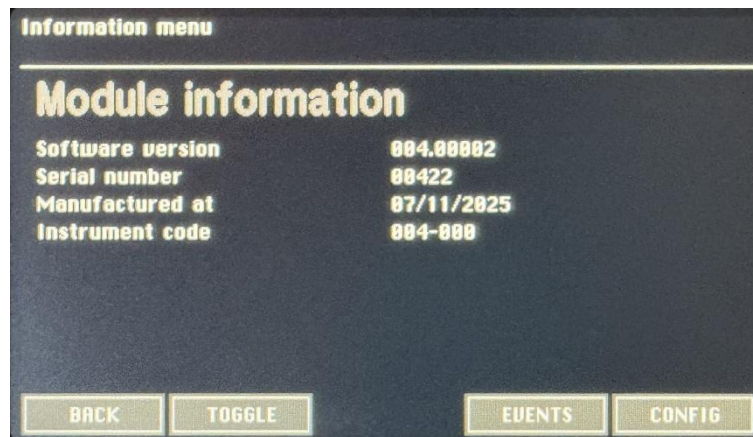

fig 5: Module information

#### Page 2 Module Settings

- Time of automatic start, if this function has been enabled. Otherwise, the text "disabled" appears instead of the time.
- Protocol set for the COM2 communication interface
- Information about the Wi-Fi connection stored in the monitor (SSID and server/port)
- Current loop output settings (data source, output signal range, and assigned value range). (The name of the data source corresponds to the unique component name. The value range refers to the physical unit of the selected measured value.)

#### Page 3: Additional module settings

- Timer operating mode (timer or periodic timer synchronized with the measurement cycle)
- Time points for switching the timer on and off, either as real time (timer mode) or as on, off, and delay intervals (periodic timer mode)

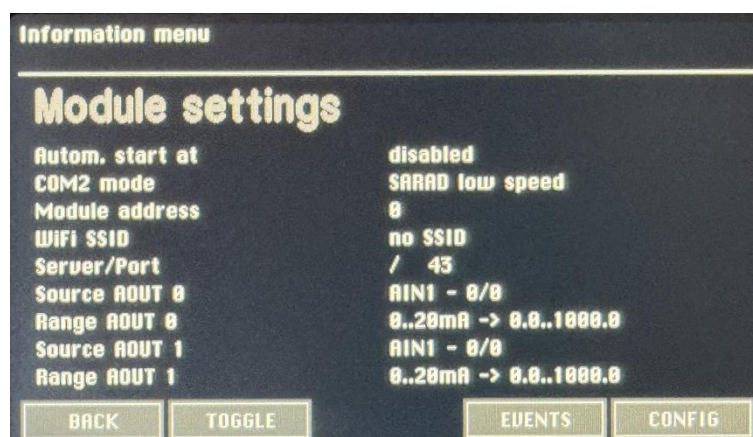

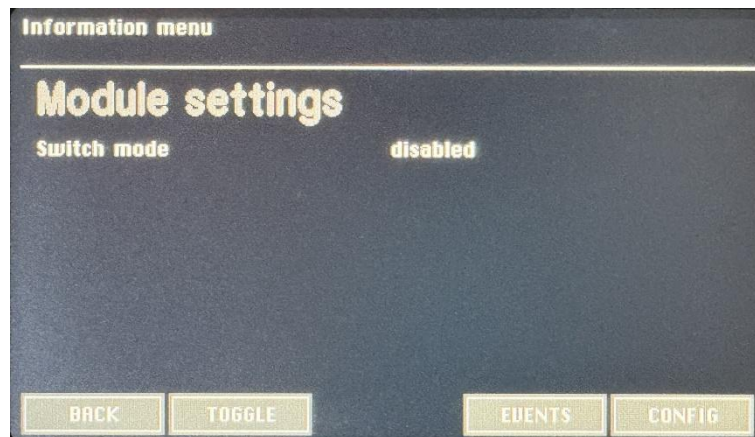
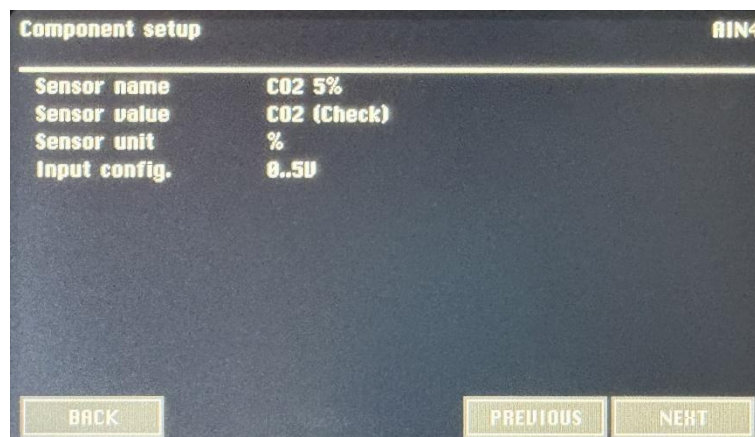

*fig 6: Module settings*

The "BACK" button returns to the main page. The "CONFIG" button allows you to switch to the display pages for the configured component parameters.

### 2. 6. 3. Display of component configuration

The current configuration parameter settings for each component can be viewed for review. To do so, click the "CONFIG" button in the information menu. Parameter changes cannot be made. The "NEXT" and "LAST" buttons can be used to select individual components.



*fig 7: Configuration of components*

If one page isn't sufficient to display all parameters, you can access additional pages using the "TOGGLE" button. You can return to the main page using the "BACK" button. The unique component name is displayed in the upper right corner.

### 2. 6. 4. Selection of measurement cycle

Touching the cycle name displayed in the main menu opens a list for selecting one of the predefined measurement cycles. A maximum of 15 different measurement cycles can be stored in the monitor. If the number of stored cycles does not fit on one display page, the "MORE" button appears, which can be used to scroll through the list. The desired measurement cycle is selected by touching the list entry. In this case, the monitor automatically returns to the main page. If you do not want to select a new cycle, press the "BACK" button.

### 2. 6. 5. Display of actual measured values

This display page is only accessible when a measurement is in progress. You access this page by touching the "RECENT" button. The display is updated every second so that the current sample value of a component is always shown. This function corresponds to that of a direct reading measuring monitor. Only the data of those components that are actually included in the measurement cycle and are currently active are displayed. Switching between the available components is done using the "NEXT" and "LAST" buttons. The alias name of the component appears in the display header.

If a component delivers more than one result, the "TOGGLE" button for switching the measured values is activated. Return to the main page is done using the "BACK" button.

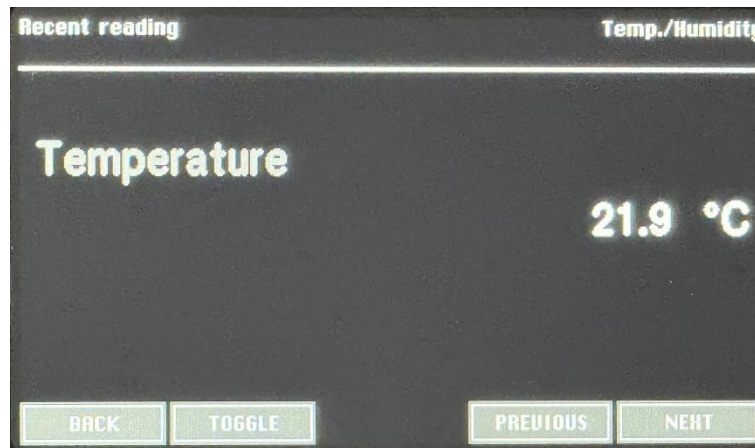

*fig 8: Display of actual measured values*

### 2. 6. 6. Display of the stored measurement values

If available, all measurement data stored on the memory card can be displayed. This function is accessible via the "INTERVAL" button during or stopped measurement. Switching between the individual components whose data is contained in the data set and selecting the desired measurement value is carried out in the same way as displaying the current values. For components that calculate multiple measured values, an additional overview page has been implemented for viewing all measurement results simultaneously.

A bar with navigation buttons appears for selecting data points within the measurement series. The middle button can be used to retrieve the most recent data set chronologically. The other buttons scroll forward or backward by one or ten data sets, respectively.

The header of the display shows the alias name of the component and the time at which the data set was saved. If the geographical position could be determined using the integrated GPS receiver, the coordinates appear in the footer. Return to the main page is achieved by pressing the "BACK" button. In addition to the highlighted mean value of the measurement for the current measurement interval, the minimum and maximum individual values within the interval are displayed below. For radiological measurements, these two values indicate the 1-sigma confidence interval determined from the counting statistics.

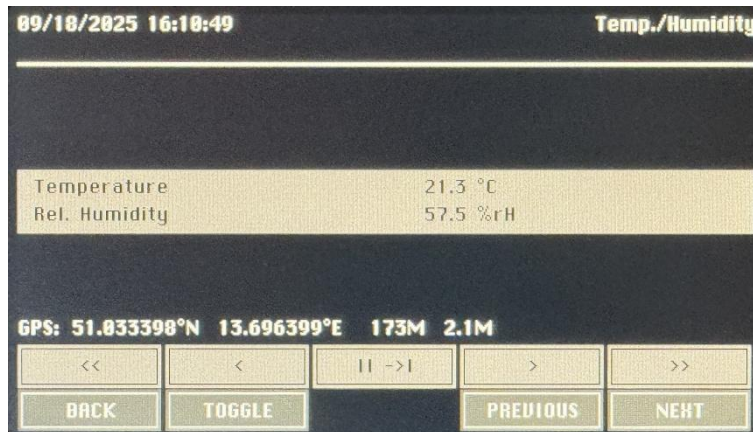

*fig 9: First display page for interval measurement data for components with multiple measured values*

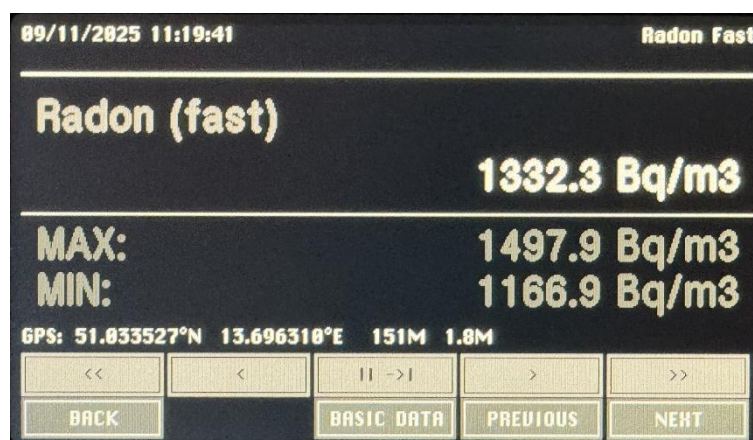

*fig 10: Display of interval measurement data*

### 2. 6. 7. Graphical display of the measurement data as a time series

All measured values available on the monitor can be displayed as a time series in a diagram. To do this, touch the "GRAPH" button in the main menu. The display is limited to the last 50 values of the current or most recently executed measurement cycle. The time axis is scaled accordingly until the limit of 50 measuring points is reached; after that, the oldest data is moved out of view with each new measured value during the measurement. Two measured variables can be displayed simultaneously. The Y-axis is always scaled automatically. Below the diagram view there are four navigation buttons with which the red cursor line can be moved by one or ten measured values. The timestamps and measured values associated with the cursor position appear above the cursor line. The desired measured variable is selected using the Select Y button. A table with the alias names of all available components appears. Now the desired component to be assigned to the left Y-axis can be selected. Since some components can generate multiple measured values, a list appears for selecting the desired value. The procedure for selecting the measurement value for the right Y-axis is then repeated. The "BACK" button returns to the main menu.

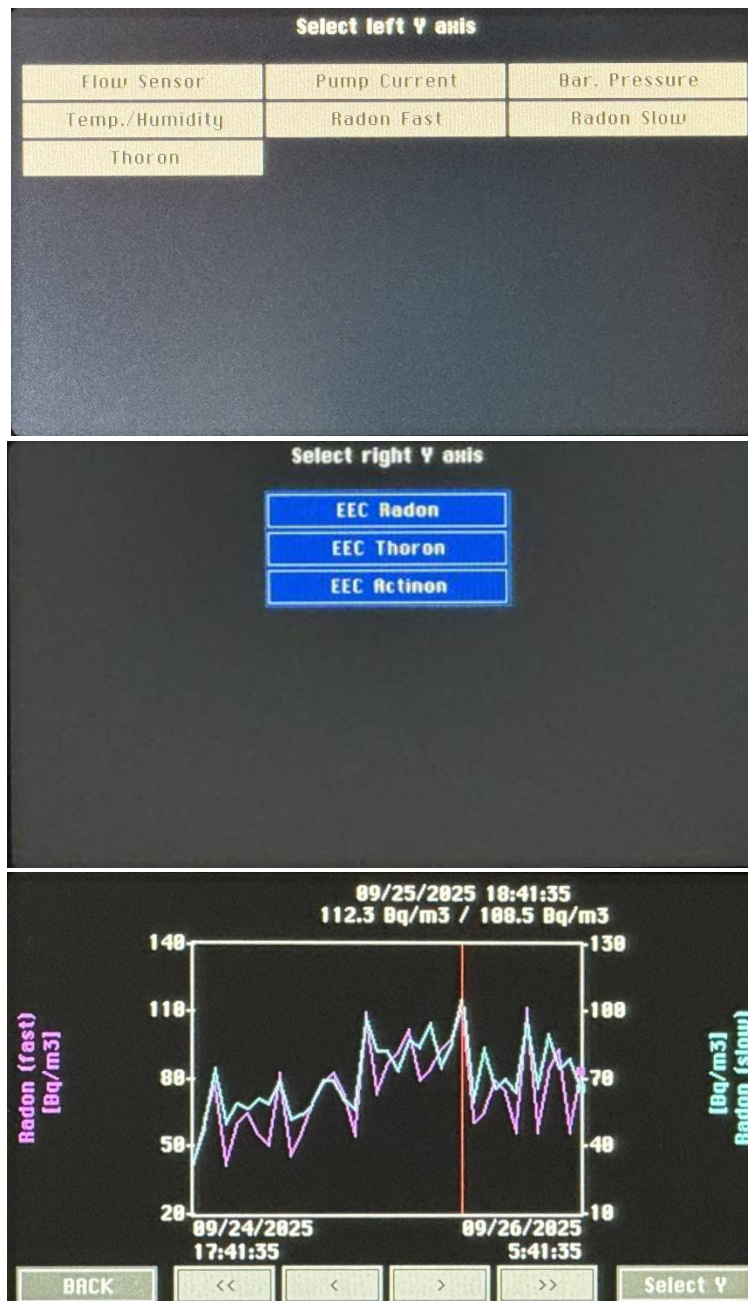

fig 11: Selection and display of series of measurements

### 2. 6. 8. Display of basic data

Some components support the display of the acquired base data used to calculate the displayed measured values. For such components, an additional button labelled "BASE DATA" appears on the interval data display page, which takes you to the corresponding display page.

#### 2. 6. 8. 1. Display of the acquired spectrum

A spectrum can be displayed for all measured values that were calculated based on an acquired energy spectrum. The spectrum is shown in the form of a diagram. A control panel appears to the right of the diagram. The light grey buttons are used for cursor navigation, while the dark grey buttons are used to control the display. The upper button switches between cursor and ROI navigation. The navigation buttons can then be used to either move the cursor or switch between the energy regions (ROI) required for calculating the measured values. The "FIT Y" button scales the diagram to the maximum

value of the spectrum. The "/10" and "x10" buttons can be used to increase or decrease the scaling of the Y-axis by a factor of 10. The lower button is used to switch the spectrum view between linear and logarithmic scaling.

When cursor navigation is selected, the counting channel, the associated energy, and the number of counting pulses contained in the counting channel appear above the white cursor line. When ROI navigation is selected, the energy range of the ROI is highlighted in colour. The energy range of the ROI and the counting pulses contained therein are displayed above it.

Depending on the number of counting channels in the energy spectrum, a correspondingly segmented bar appears below the diagram, allowing the spectrum to be scrolled left or right across the diagram area. The yellow bar below the scroll bar indicates the currently displayed spectrum range.

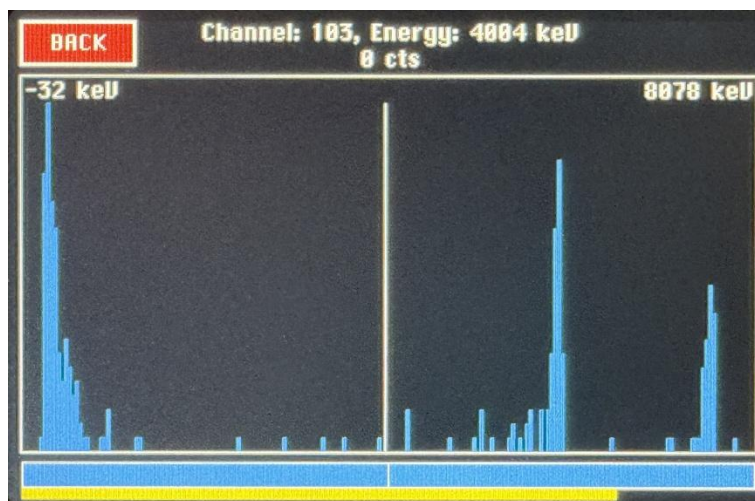
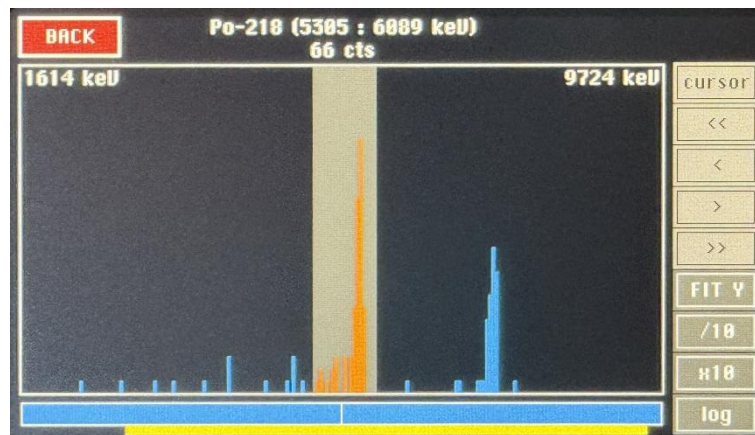

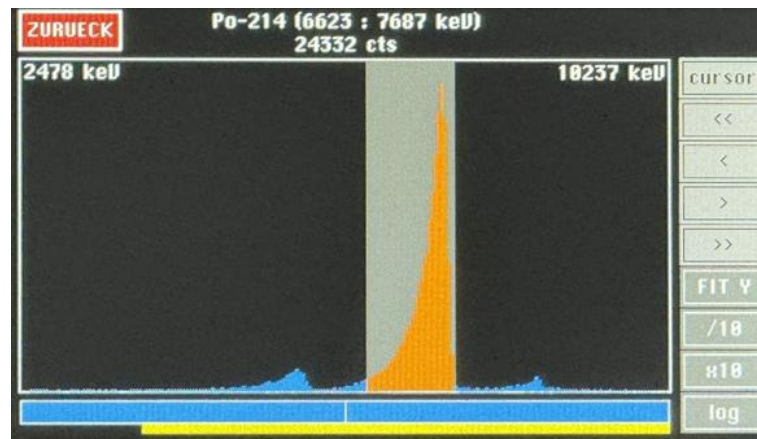

fig 12: Display of spectra (Cursor- and ROI-navigation)

### 2. 6. 9. Alarm-display

As soon as a new alarm occurs on the monitor, it automatically switches to the alarm display page. If the display was deactivated, it will be activated. The display contains a list of all existing alarms in the form of a text line. The current status of an alarm is indicated by the text colour, which is assigned as follows:

- Red: New alarms, only when the alarm menu is first accessed
- Yellow: Alarm situation still exists; alarm confirmation has not yet been received
- Green: Alarm situation still exists; alarm has already been confirmed
- White: Alarm situation no longer exists; alarm confirmation has not yet been received

The alarm is confirmed using the "CONFIRM" button in the bottom right corner of the display. The BACK button returns to the main menu. As long as alarm situations exist or there are unconfirmed alarms, a red button labelled "ALARM" appears at the top centre of the main menu. This button can be used to access the alarm display page at any time.

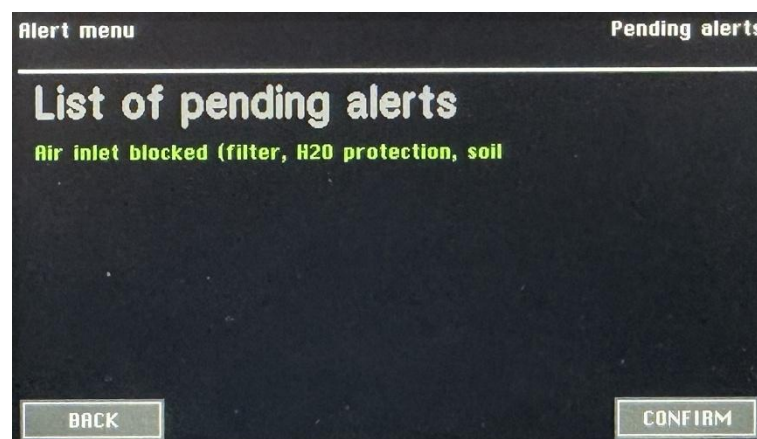
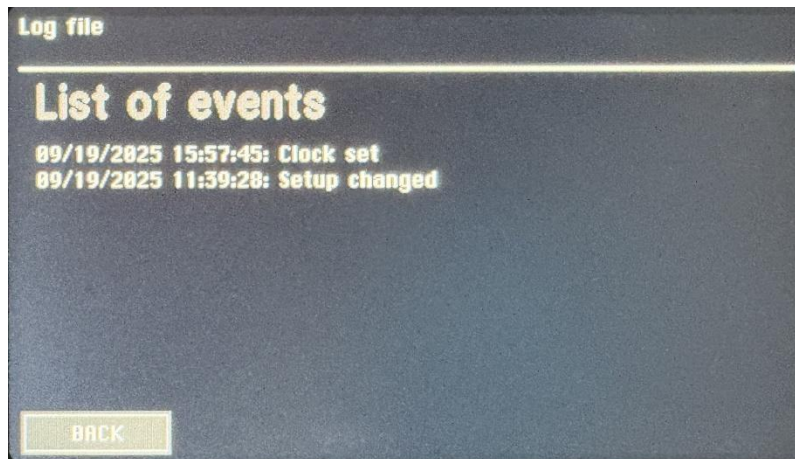

fig 13: Display of alerts (Cursor-navigation)

### 2. 6. 10. Display of event memory

The entries in the event log can be displayed from the main menu using the "EVENTS" button. The output is in reverse chronological order, i.e. the most recent event is at the top of the list. The "MORE" button scrolls to the end of the event list. The events are output as text messages. For some event types, the text contains additional information regarding the origin of the event, e.g. whether the event

was triggered via the touch screen or via one of the communication interfaces. When selecting a cycle, the index of the selected cycle is specified. If alarms have occurred, a bit mask is displayed. The index of a component corresponds to its position within the bit mask. A set bit (a "1" is displayed) signals the origin of the alarm(s) that have occurred. The "BACK" button takes you back to the main menu.



*fig 14: Display of events*

## 2. 7. Setup (timer, synchronous start, display switch off)

### 2. 7. 1. Timer

Using the integrated timer, the 12 V DC system voltage can be switched to an external load (e.g., relay, solenoid valve, modem, etc.) for a specific period of time. The maximum current must not exceed 400 mA.

The switched voltage is available at the "AUX2" jack. The timer can operate in two modes ("Clock Switch Mode"):

#### 1. Timer

In this mode, two times of day are specified for switching on and off. The switching process then occurs daily at these times. The monitor's internal real-time clock serves as the time base.

#### 2. Periodical timer

Here, a period for the on and off states, as well as an additional switch-on delay, can be defined. The timer function is synchronized with the start of a measurement. After the start, the monitor waits for the switch-on delay period (which can also be set to 0). The voltage is then switched on for the switch-on period and, after this period has elapsed, switched off for the switch-off period. This process is repeated periodically until the end of the measurement. If the timer is not to be used, it can be deactivated by selecting the operating modes.

### 2. 7. 2. Synchronous start at a set time of day

If multiple measuring monitors at different locations need to be synchronized, we recommend using the synchronous start function. A time of day can be set at which the currently selected measurement cycle will automatically start. The monitor's internal real-time clock serves as the time reference. The clocks of all monitors to be synchronized should be set to the same time beforehand.

### 2. 7. 3. Display shutdown interval

To reduce power consumption, the display is deactivated after a configurable period of time (starting from the last touchscreen operation). The time period can be set from 1 to 255 seconds.

---

## 2. 8. The integrated GPS receiver

The monitor is equipped with a GPS receiver. The coordinates (longitude, latitude), altitude, and the deviation underlying the positioning are saved for each data set. This information is shown on the monitor display (interval data menu).

If the monitor is moved within a measurement interval, the time-weighted geographic centre is saved. The current position is determined every 5 seconds, and the average values for longitude, latitude, and altitude are calculated for the entire measurement interval.

The specified deviation is an indicator of the navigation accuracy (satellite signal) underlying the positioning. The actual deviation may be greater.

Coordinates are displayed on the monitor in decimal degrees (max. 6 decimal places), each with the compass direction indicated.

If the reception quality is too poor, the message "No signal" appears on the display instead of the coordinates. After starting a measurement, the module needs a few minutes to acquire all satellites available for navigation.

### 3. Sensors and actuators in the EQF 3320

The following describes the sensors available in the monitor, their assignment to the DACM32 components, and the measured values generated from the sensor signals. The configuration of the respective components is not explicitly discussed, as this was defined by the manufacturer for the monitor. The text provides the unique component names and, in parentheses, the alias names of the components. Both names are used as needed on the various display pages.

#### 3. 1. Radon gas measurement, temperature and relative humidity

The monitor has an internal radon measurement chamber as part of a closed air circuit between the two hose nipples "IN" and "OUT." The measuring air is pumped through the air circuit by a regulated pump with a constant flow rate 0.5 l/min.

##### 3. 1. 1. Measuring principle

The radon activity concentration is determined based on the short-lived radon decay products formed in the monitor's measuring chamber. Decay products already present in the measuring air are retained by a filter system. Immediately after the decay of the radon (alpha emitter), the remaining Po-218 atom exists as a positive ion, as the emitted alpha particle tears electrons from the atomic shell. These ions are deposited on the surface of the semiconductor detector by an electrostatic field applied between the chamber wall and the detector. The number of Po-218 ions collected per unit time is proportional to the radon concentration in the measuring chamber.

Po-218, also an alpha emitter, decays with a half-life of 3.097 minutes on the surface of the detector, of which 50% of the decays (half-space) are recorded. Activity equilibrium between radon and Po-218 is reached after approximately 5 half-lives, or about 15 minutes. This determines the fastest possible response time of the monitor to a sudden change in radon concentration.

According to the decay sequence, the radioactive decay process continues with the two beta emitters Pb-214 and Bi-214, followed by the alpha decay of the resulting Po-214. Consequently, each Po-218 decay is detected again by the decay of Po-214 on the detector. However, this decay is delayed by the half-lives of the intervening nuclides, so that activity equilibrium between Po-218 and Po-214 is only reached after approximately two hours.

The emission energies of Po-218 and Po-214 are different, so both nuclides can be separated using alpha spectroscopy.

Spectroscopic monitors offer a choice between two methods for calculating radon concentration. In the so-called "slow mode," both Po-218 and Po-214 are included in the calculation, while in "fast mode," only the "fast" Po-218 is used.

The advantage of "fast mode" is the rapid response time to occurring concentration changes, while in "slow mode," the sensitivity (detected decays per time and radon concentration) is doubled. This increased sensitivity reduces the statistical error of the measurement, which is directly determined by the number of decays recorded within the measurement.

In the case of thoron (Rn-220), the measurement is carried out exclusively using the direct progeny Po-216. Po-216 is also deposited electrostatically on the detector surface in the same way as Po-218 (see above). Since the half-life of Po-216 is less than one second, the equilibrium between thoron and Po-216 activity concentration is virtually instantaneous, and thus the measured value is available immediately.

The half-life of the Po-216 progeny Pb-212, at more than ten hours, is too long for a reasonably timely measurement, so the resulting alpha emitters Po-212 and Bi-212 are detected but not used for

concentration determination. The thoron progeny products are also separated using alpha spectroscopy.

There is temperature/humidity sensor located in the device's internal air circuit to determine the humidity in the measurement chamber. The sensor detects possible condensation inside the chamber. Due to the variable power consumption of the instrument the sensor readings do not represent the environmental conditions. Therefore, an external sensor which can be connected to the "AUX2" socket is part of delivery.

### **3. 1. 2. DACM32-components for the radon measurement**

The amplified signal from the semiconductor detector is connected to the input of the spectrometer component SPEC1 (radon). This component separately records the count rates of the individual radon decay products Po-218 (for "fast mode"), Po-218 + Po-214 (for "slow mode"), and Po-216 (for thoron). Humidity measurement is performed by component I2C1 (SHT21), which integrates a digital humidity/temperature sensor. The radon concentration is calculated from the count rate and the measured humidity using three calculator components: CALC1 (radon (fast)), CALC2 (radon (slow)), and CALC3 (thoron).

### **3. 1. 3. Display of measuring values for radon, temperature and humidity**

To calculate a radon measurement value, an alpha spectrum is required, which is acquired over the period of the measurement interval and is only available at its end. The calculated radon measurement values (CALC1/2/3) are therefore only displayed on the interval data display page. To make the acquisition visible during an interval, the total counting pulses of the spectrometer component SPEC1 are shown on the current data display page. Temperature and humidity values are displayed both as current measured values and as average values. Note: Since temperature and humidity are measured in the air circuit, the measurement results are only of limited use for characterizing the ambient conditions. This is particularly the case if the measuring air is drawn in from another location or if the monitor is heated (e.g., by sunlight or during battery charging).

## **3. 2. Particle size specific Radon progeny measurement**

The Radon/Thoron progeny measurement is carried out using a freely positionable measuring head, which is connected to the air circuit and electronics of the basic unit via a cable (connection to socket 'AUX1') and an air tube (connection to nipple 'IN').

For reproducible measurements of radon decay products and other radioactive aerosols, a constant flow rate 1.5 l/min ensures both consistent sensitivity and consistent airflow conditions. The latter is necessary to avoid variable particle size-dependent collection losses. The air flow is generated by an internal pump.

### **3. 2. 1. Functional principle**

The Po-218 and Po-216 produced by the radon decay and their subsequent decay products exist as atoms until they attach themselves to particles already present in the air. A real atmosphere therefore contains both unattached and attached decay products. The attachment process and thus the ratio of the two fractions depend on the present particle concentration. The diameter of radon decay product atoms is approximately 0.2 nm, while typical indoor air atmospheres have a particle size spectrum ranging from 50 nm to 500 nm. The two fractions behave very differently in physical terms, which is important for dose assessment and requires two different separation media for measurement.

Due to their low mass, unattached daughter products perform strong thermal motion. When they are passed through a specially designed screen at a suitable velocity, this motion causes them to collide

with and deposit on the screen wires. Larger particles can pass through the grid unaffected. The screen is located directly at the air inlet of the sampling head. Deposition losses are minimised by the small surface area of the sampling head and the distance from the basic unit by the stand mount. The attached fraction of the daughter products follows the air flow to a filter at the air outlet of the measuring head, where they are collected. The daughter product activity collected on the screen and the filter is obtained using semiconductor detectors and subsequent alpha spectroscopy.

### ***3.2.1.1. The 'cut-off' particle size***

The process of depositing unattached daughter products on the screen does not allow for sharp size separation. Rather, it is a statistical process in which the probability of deposition increases as the particle size decreases. The 'cut-off' particle size refers to the particle size that is deposited on the screen with a probability of 50%, i.e. half of all particles of this size are deposited, while the other half pass through the screen. The separation probability of particles with one tenth of the cut-off particle size is approximately 99%, while for particles with ten times the cut-off particle size it is approximately 1%. The sampling head was designed for a cut-off particle size of 5 nm. This is about ten times larger than the size of atomic daughter products and also ten times smaller than the lower limit of typical size distributions in indoor areas. Thus, the two fractions are almost completely separated.

### ***3.2.1.2. Thoron progeny***

To achieve practically usable response times for changes in the thoron decay product concentration, the calculation is performed by differentiating the time course of the detected Po-212 activities on the filter. Since in this case the difference of the count pulses from two consecutive measurement intervals must be calculated, the calculated value has a significantly larger statistical fluctuation range. Therefore, a sufficient large measurement interval should always be selected. In practice, intervals of one to three hours have proven effective. These are sufficiently large to record daily variations and correspond with the response time of the Rn-222 decay product measurement.

### ***3.2.1.3. Compliance with calibration parameters***

The sensitivity of the device, i.e. the amount of daughter products collected on the screen and filter, is linearly dependent on the air flow through the filter. The device constants were determined during calibration for the nominal flow rate specified in the data sheet. Any change to the nominal flow rate by the customer therefore requires a change to the device constants as part of a recalibration. The grid was parameterised according to the nominal flow rate. A change in the volume flow also results in a shift in the 'cut-off' particle size. Calibration is based on the properties of the screen and the filter material used. Original materials from the manufacturer must always be used to ensure reliable measurement results.

## **3.2.2. DACM32-components for radon progeny**

The output signal of the filter detector is connected to the SPEC2 spectrometer module while the screen detector is connected to the spectrometer module SPEC3. The spectrometer modules provide spectra for each counting interval to determine the count rates and calculate the progeny activity concentrations.

## **3.2.3. Display of radon progeny products**

The progeny concentrations for attached and unattached fraction are displayed on separate pages (SPEC2, SPEC3). The display shows the EEC (equilibrium equivalent concentration) as well as PAEC (potential alpha energy concentration) for Radon and Thoron daughters. Using the TOGGLE button, the various measured values and the corresponding confidence interval (1-sigma) can be displayed.

### 3. 3. Flow measurement, flow control and pump current

For reproducible measurements of radon decay products and other radioactive aerosols, a constant flow rate ensures both consistent sensitivity and consistent airflow conditions. The latter is necessary to avoid variable particle size-dependent collection losses. The air flow is generated by an internal pump.

#### 3. 3. 1. Functional principle

The flow rate is measured using a calorimetric mass flow sensor. This also serves as the actual value transmitter for flow control. A mass flow sensor always measures the air volume that would occupy the displayed volume under standard conditions. For example, if the ambient pressure is 10% lower, the flow rate must also be increased by 10% to achieve the same air flow rate. The measuring air flows through the flow sensor as part of the internal air circuit. The control loop gradually increases or decreases the pump flow if the sensor's measured value deviates upwards or downwards from the nominal flow (setpoint). If the filter is too heavily contaminated, the pump reaches its maximum capacity, so that further contamination will prevent the nominal flow rate from being achieved. Therefore, the monitor's alarm system generates a warning signal at 80% of the pump capacity.

Every pump is a mechanical component subject to wear. At the end of its service life or in the event of a defect, the pump's operating current can increase significantly, even leading to a short circuit. To protect the electronics, the instrument monitors the pump current and the alarm system stops the measurement if a limit value is exceeded.

#### 3. 3. 2. DACM32-components for internal air circuit

The flow sensor output is connected to analog input AIN6, and the pump current and pump voltage signals are connected to analog inputs AIN6 and AIN7. The pump power is controlled by the controller component REG1. The controller component generates a control voltage that can be used to vary the pump power.

#### 3. 3. 3. Display of the measured values of the air circuit

The current flow rate measurement (AIN6) and the pump current (AIN7) are displayed in the corresponding physical unit. The pump voltage (AIN8) serves as an indicator of the required pump power and thus the condition of the filter. The maximum possible pump voltage determines the maximum pump power and thus the control limit for the flow. The control limit is equated with a filter occupancy of 100%. A new filter would theoretically correspond to a filter occupancy of 0%. However, the lower value is factory-set to 15%, as the required pump power can vary within certain limits depending on the ambient conditions and filter. Instead of the pump voltage, the monitor displays the filter occupancy in percent. Each measured value of the air circuit has its own display page.

### 3. 4. Barometric pressure, differential pressure (option)

The monitor is equipped with a barometric pressure sensor as standard, and an optional differential pressure sensor for small differential pressures. In the standard monitor, the pressure sensor terminal is connected to the monitor's centre tube nipple labelled "p." If a differential pressure sensor is present, the vacuum sensor terminal is connected to the hose nipple. The unconnected terminals are open, i.e., they are subjected to ambient pressure. Note: The pressures applied to the "p" hose nipple must not exceed the maximum permissible pressure values specified in the data sheet. The I2C2 component is used for the barometric pressure sensor; for the optional differential pressure sensor, the analogous input AIN5 or the I2C3 component is used, depending on the configuration. The pressure values are each displayed on a separate display page.

### 3. 5. Warning and alarm lights

The basic unit has a signal LED labelled "!" directly above the "WAKE" button. This LED illuminates both in the event of warnings and alarms. The signal LED is connected to the DOUT8 switching output. Two additional signal lights can be connected to the "AUX2" socket. A signal tower (yellow/red combination) is included upon request, or two separate signal lights (yellow and red) can be mounted on the lid of the measuring case. The yellow light indicates warnings regarding the operating status of the monitor (DOUT1), while the red light (DOUT2) is assigned to radiometric alarms.

### 3. 6. The connectors „AUX1“ and „AUX2“

The two accessory connectors allow the connection of external sensors and actuators, as well as accessories for special measurement tasks. Caution: Only components supplied by SARAD may be connected to these two sockets. Improper use may damage the monitor's electronics.

The "AUX1" socket is primarily intended for connecting radiation sensors, while the "AUX2" socket provides external connections for various DACM32 components. The following tables show the socket assignments and signal usage in the EQF 3320.

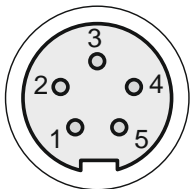

Socket "AUX1" (Binder Series 712, 5-pin), front view of the socket

Pin	Signal	Use
1	SPEC2	Pulse input for spectrometer component, detector signal of the progeny product measuring head
2	V+	supply voltage for progeny product measuring head
3	SPEC3	Pulse input for spectrometer component, filter-detector signal of the progeny sampling head
4	BIAS	Bias voltage for progeny measuring head
5	GND	Reference potential

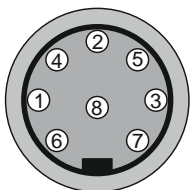

Socket „AUX2“ (Binder Series 680 – DIN 8-pin), front view of the socket

Pin	Signal	Use
1	DOUT1	Switching output for optional accessories, controlled by the alarm system. A voltage of +12 VDC is applied when activated.
2	AIN1	Analog input, no use in EQF 3320
3	AGND	Reference potential for AIN1, AIN2, and CMP1, no use in EQF 3320
4	DOUT2	Switching output for optional accessories, controlled by the alarm system. A voltage of +12 VDC is applied when activated.
5	AIN2	Analog input, no use in EQF 3320
6	Clock-Switch	Switching output of the timer. A voltage of +12 VDC is applied when activated, no use in EQF 3320

---

7	PGND	Reference potential for +12 VDC, Ground wire for red and yellow signal lights
8	CMP1/CNT1	Comparator and counter input e.g. for dose rate probe

## 4. EQF 3320 monitor configuration

### 4.1. Predefined measuring cycles

The following measuring cycles are stored in the delivered monitor:

Name of cycle	Description
Rn+FP 15 min	Continuous radon/thoron and radon/thoron progeny measurement with 15-minute measurement intervals
Rn+FP 30 min	Continuous radon/thoron and radon/thoron progeny measurement with 30-minute measurement intervals
Rn+FP 1 h	Continuous radon/thoron measurement and radon/thoron progeny measurement with 1-hour measurement intervals
Rn+FP 2 h	Continuous radon/thoron and radon/thoron progeny measurement with 2-hour measurement intervals
Signal-Test	Test the "!" signal LED and, if present, the external signal lights (flashing)

### 4.2. Predefined warnings and alarms

The DACM32 platform offers a highly flexible alarm system that allows any user-specific alarms and warnings to be generated. The following alarms are configured by default:

Measuring value (Alarm-source)	Hint	Signal	Alarm message
Pump controller (AIN8)	Pump capacity >80 %	LED front plate, ext. Yellow lamp	"Air inlet blocked or water inlet protection!"
Battery voltage (BATT)	Battery voltage less than 11.6 V	LED front plate, ext. Yellow lamp	"Battery discharged, please charge!"
Pump current (AIN7)	Pump current >300 mA	Measurement will be stopped immediately	Alarm can be read in the event log
Optional: Differential pressure (AIN5 or I2C4)	Differential pressure too low (e.g., if no filter was inserted or hose is not connected)	LED front plate, ext. Yellow lamp	"No pressure drop, check filter!"
Radon concentration (SPEC1)	Check at the end of the measuring cycle	LED front plate, ext. red lamp	„Radon limit exceeded“
Radon progeny product concentration EEC (SPEC2)	Check at the end of the measuring cycle	LED front plate, ext. red lamp	„EEC limit exceeded“

---

Humidity sensor (I2C2)	Humidity in the internal air circuit >96%	LED front plate, ext. red lamp	"Risk of condensation!"
------------------------	---	--------------------------------	-------------------------

Hint: The alarm check is only possible if the component that provides the measured value is activated in the measurement cycle. When defining custom measurement cycles, ensure that all components listed in the table are activated.

The battery voltage is monitored independently of the alarm system. At a voltage of 11.2 V, the measurement is automatically stopped without additional signalling. A corresponding entry is made in the event log.

The alarm signalling with yellow and red external lights is only activated if the monitor is supplied with a measuring case or a light column (accessory).

## 5. Important hints on operating the monitor

### 5.1. Vibrations and strong electromagnetic fields

Continuous strong mechanical shocks and vibrations can affect the detector signal due to the piezoelectric effect and must be avoided. The monitor should not be operated in close proximity to strong and high-frequency electromagnetic fields (e.g., placing the monitor on high-voltage switchgear or placing mobile phones on the monitor).

### 5.2. Aggressive Gases

Due to the operating principle, all sensors, semiconductor detectors, and mechanical components come into contact with the measuring air. Aggressive gases can damage or destroy the sensitive surfaces of the sensors/detectors or contact systems. This can lead to measurement errors or malfunction. Avoid using the monitor in the presence of aggressive gases.

### 5.3. Environmental conditions

The ambient conditions specified in the data sheet must be observed. Operating outside the specified limits may result in incorrect measured values or limit the functionality of the monitor. If the monitor must be used under such conditions, please consult the manufacturer.

### 5.4. Check up of the alpha spectra

Recording and displaying alpha spectra is the most powerful tool for quality assurance of radon and progeny measurements. Both the radon measurement chamber and the progeny sensor head provide characteristic energy spectra that the user can reliably evaluate after a short period of time. All radon and thoron progeny generate characteristic peaks in the spectrum, the shape and position of which indicate the proper functioning of the monitor. Less experienced users should save the initial measurement results after delivery of the monitor so that "reference spectra" are available for later comparison. A quick look at the acquired alpha spectra should always be part of good measurement practice.

### 5.5. Avoiding condensation

The formation of condensation in the monitor must be avoided. Condensation can occur if the monitor temperature is below the temperature of the measuring air and the dew point is exceeded upon cooling. Typical scenarios are soil air measurements in winter or immediate measurements in humid, warm rooms after transport at low temperatures. In such cases, the monitor must be sufficiently warmed before use. Damage to the monitor is not expected, but it may impair the measurement. If, for example, constant temperature changes are expected in a stationary installation under humid ambient conditions, a cooling and condensation monitor must be installed upstream or the monitor must be placed in a heated measuring cabinet. Depending on the monitor type, rotary vane pumps are used to generate the airflow. The surfaces of the compressors can corrode if surface moisture is present, which can lead to reduced pumping performance or even inoperability. After measurements under humid conditions, a fifteen-minute measurement should be performed in a dry environment to remove any moisture present from the internal air circuit.

### 5.6. Water inlet protection

Especially when measuring soil gas or water samples, it is important to ensure that no water can enter the internal air circuit. The pump's power is sufficient to suck water even from deeper sample boreholes. In this case, all sensors come into direct contact with water. For this reason, the water inlet

protection must always be used. This is included with the "ULTRA" versions of the monitor and is available as an accessory for the standard monitor. This consists of a container with a float switch that is inserted between the soil gas probe or water probe and the air inlet of the monitor. If water enters, the float switch switches off the pump via an additional socket on the monitor. Note: The container must always be used vertically, i.e. with the connections pointing upwards (for monitors with a retaining clamp for the water inlet protection, the monitor must be operated in the appropriate position). It is recommended that a functional test be carried out before each use. To do this, start a test measurement and then turn the empty container with the connections facing downwards. The pump must stop immediately.

If water is accidentally sucked in, first disconnect the hose connecting the container to the air inlet. Then, disconnect the second hose from the container and the connecting cable from the monitor. The container can now be removed from the holder, unscrewed (turn the lid clockwise), and emptied. The surfaces should be dried with a cloth. Any water contained in the hoses should also be removed. When closing the container lid, ensure that the rubber seal is correctly seated. The container should be checked for leaks.

### **5. 7. Filter at the air inlet of the monitor**

The internal gas circuit contains a multi-stage filter to prevent radon decay products already present in the sample air from entering the radon measurement chamber. This filter is not accessible from the outside and is normally maintenance-free. This requires that dust and other particles are removed from the sample air beforehand. If the decay product measuring head is not used, the supplied syringe filter should be connected to the monitor's air inlet instead. This filter should be replaced if significant contamination is visible or if the required pumping capacity is significantly increased.

### **5. 8. Rechargeable battery**

The lifespan of the built-in battery is reduced if it is deeply discharged or stored in a discharged state for extended periods. Even a fully charged battery will reduce its lifespan. For this reason, the battery should be subjected to a charge and discharge cycle every three months. This also applies if the monitor is not used for an extended period of time (the battery is subject to slight self-discharge, i.e., it loses capacity even when no power is drawn). Before the monitor is not used for an extended period of time, the battery should be charged to approximately 13V, the monitor turned off, and the fuse removed. Note: Deep discharge of the battery usually leads to a defect. This is detected by the charger, so the charging process will not begin.

### **5. 9. Hints for the sampling head for progeny**

#### **5. 9. 1. Connection and placing**

The sampling head is a separate unit that can be placed either on the accessory adapter of the device, on the measuring case or freely in the room. It is mounted using an M16x1 thread and knurled nut (7) on the mounting foot (6). The stand (5) should be positioned vertically. The mounting bracket can be adjusted on the accessory adapter according to the device positioning. The air flow through the filter is generated by the basic device, so the hose connection of the sampling head (10) must be connected to the air inlet of the basic device (1) with a hose. In addition, the electrical connection to the device must be established by connecting the connection cable to the 'AUX1' socket on the front panel of the device. The plugs must be locked with the screw sleeve and the hose connection must be checked for leaks.

Unattached progeny will be easily deposited on surfaces due to thermal movement. This results in a depletion of aerosols and radon daughter products in their vicinity. For this reason, the sampling head should not be placed near surfaces.

### 5.9.2. Replacing the filter

The filter must be replaced at the latest when a corresponding warning appears on the device. It is advisable to replace the filter earlier, as the energy consumption of the pump increases with increasing contamination and the battery life of the device is reduced.

To replace the filter, the union nut (11) must be removed. The filter pressure plate (9) can then be removed. The filter may stick to the tube (4) due to the sealing material.

In this case, the filter must be removed with tweezers or similar. **CAUTION:** Behind the filter is the semiconductor detector, which must not be touched under any circumstances. The new filter should be positioned centrally with the seal on the filter pressure plate. The pressure plate can then be inserted into the filter support and secured with the filter nut. The filter support has two pins on the inside that must engage in the side grooves of the pressure plate to prevent the filter from twisting when the filter nut is tightened.

### 5.9.3. Screen cleaning and replacement

To ensure correct measurement, there must be no dust or dirt deposits on the screen. The screen was selected with a maximum mesh size so that even fine dust can pass through it. However, if larger particles such as fluff, flakes or large particles are present in the measured air, this will result in contamination and blockage of the screen. This causes the screen to act as a filter, so that attached daughter products are also deposited. In this case, neither the measurement of the unattached nor the attached fraction is correct. The condition of the screen should be checked before and after each use and the screen should be cleaned if necessary. The screen is made of stainless steel, so it can also be cleaned using solvents. **CAUTION: The screen must always be removed from the sampling head for cleaning. Solvents damage the surface of the semiconductor detector!** To remove the grid, the union nut (2) must be removed from the grid support (3).

### 5.9.4. Limitations of the sampling head

The sampling head cannot be used in environments that cause constant contamination of the grid. In most cases, this is also physically impractical, as the part of unattached by-products is negligible. A workaround is to remove the screen so that all daughter products can reach the filter. It should be noted that some of the unattached daughter products that may be present are deposited on the inner surfaces of the sampling head and are not included in the measurement. A better alternative is to use a measuring head for size-independent determination of the daughter product concentration, such as the one used in the EQF 3300. With this measuring head, separation losses are minimised by the design of the air intake. Both measuring heads can alternatively be connected to the 'AUX1' socket on the base unit. **ATTENTION: When using without a grid, always attach the protective cap for the grid detector, which is available as an accessory.**

---

## 6. Use of accessories

### 6.1. Accessory adapter

For some accessories (e.g. water ingress protection) it is necessary or advisable to permanently connect them to the monitor. For this purpose, there is an accessory adapter on the left side panel of the housing. This has a central threaded M6 hole for fastening and a series of opposite holes for positioning the accessories. The attachment is made using the counterpart that matches the respective accessory, which has two tabs for the positioning holes and a central hole for fastening with an M6 screw. The positioning holes are arranged in such a way that vertical positioning is guaranteed when the monitor is lying down (rack), standing up (case) and when using the stand bracket (table). The user must make the appropriate adjustment depending on the position of the monitor.

### 6.2. Case for harsh environmental conditions

If the monitor is to be used in harsh environmental conditions, the use of the optionally available measuring case is recommended. This is dust- and waterproof and features tube connections for transporting the measuring air to and from the monitor. The power supply socket on the case allows continuous operation of the monitor with the case closed (the cable extension in the case must be plugged into the "DC" socket). Depending on the model, one or two signal lights are mounted on the top of the case lid to indicate warnings and alarms. The connection cable for the signal lights is connected to the "AUX2" socket on the front of the monitor. When closing the case lid, care must be taken to ensure that no air tubes or cables are kinked. The measuring case for the EQF 3320 has an additional hole for the connection cable and the installation of the downstream product measuring head. The connection cable must be connected to the "AUX1" socket accordingly.

Note: The Rn/Th progeny sampling head itself is not protected against water ingress. If there is a risk of dripping water occurring at the measuring location, appropriate protective equipment must be provided.

### 6.3. Light tower

The light tower is used to signal warning and alarm conditions. The bright 360° signal lights ensure good visibility even from greater distances. The light column is connected to the monitor's "AUX2" socket. It is controlled via the "DOUT1" (yellow) and "DOUT2" (red) switching outputs. The light column can be freely positioned in the room using either a mounting bracket on the monitor's accessory adapter or a suitable cable extension.

### 6.4. Gamma dose rate probe

The EQF 3320 offers the option of connecting a probe for measuring the gamma local dose rate to the 'AUX2' accessory socket. The probe's pulse signal is connected to the 'CMP1/CNT1' comparator-counter combination via the plug. Power is supplied via the 'DOUT1' switching output. The probe is integrated into the measurement by activating the components (CNT1, CMP1, DOUT1) in the measurement cycles and entering their configuration parameters. This is done by the manufacturer when the probe is ordered together with the device. When the probe is reordered, configuration and measurement cycle files are supplied and can be transferred to the device by the user. The measured values of the local dose rate will appear automatically in the display and the measurement data files. SARAD offers two different gamma probes with measuring ranges of 1 mSv/h and 100 mSv/h. A mounting clip for attachment to the accessory adapter is included in the scope of delivery.

## 6. 5. Soil gas probe

### 6. 5. 1. Hints for soil gas measurements

Soil gas measurements are primarily used to estimate potential radon contamination in newly constructed buildings. Based on the results of such measurements, decisions about necessary radon protection measures can be made even before construction begins.

A major source of error in soil gas measurements is inadequate sealing of the soil gas probe from the surrounding soil. This creates the risk of drawing in a greater or lesser amount of fresh air.

When measuring soil gas over extended periods, changes in ambient parameters must always be expected. There is a risk of water being sucked in after rainfall. Condensation is to be expected if the monitor cools down while the soil is still moist and warm. For this reason, additional precautions must be taken. Since these must be individually adapted to the local situation, our staff should be consulted in advance.

### 6. 5. 3. Connection of soil gas probe

When measuring soil gas, always use the water inlet protection. Its air outlet is connected directly to the "IN" hose nipple on the front panel of the monitor. The filter supplied with the soil probe must be connected to the water inlet of the water inlet protection monitor (note the marked flow direction). This filter has lower air resistance than the syringe filter normally used.

### 6. 5. 4. Use of the simple soil gas probe

Simple soil gas probes (impact probes) have become established as the standard method for in-situ soil gas measurements. When used correctly, they enable the quick and reliable sampling of soil gas. An impact probe consists of a one-meter-long tube with a so-called "lost tip" attached to its lower end. Using a hammer, the tube is driven tip-first into the soil. A percussion sleeve is attached to protect the end of the tube during the driving process. The probe has reached the correct position when the upper end still protrudes approximately 15 cm from the ground. To achieve maximum sealing of the probe against the surrounding soil, the tube must be driven in straight and without any pendulum motion. The drive rod is then inserted into the tube, and the lost tip is driven out of the tube with a few hammer blows (using the percussion sleeve). The process is complete when the upper end of the drive rod still protrudes approximately 1 cm from the tube. The drive rod can now be withdrawn, and the connecting hose to the monitor can be attached to the upper end of the tube. The hose connection must be checked for leaks before each measurement. A silicone hose with an inner diameter of 8 mm should always be used to connect the probe. Always use the water inlet protection monitor between the probe and the monitor's air inlet. Now start the soil gas measurement cycle on the monitor to measure the radon concentration.

## 6. 6. Aqua-Kit for determination of radon concentration in water samples

### 6. 6. 1. Measuring principle and accessory

The determination of radon concentration in water samples is based on the solubility equilibrium of radon between water and air. This is highly dependent on the temperature of the media and must be taken into account in the calculation. The physical and mathematical principles can be found in the application note "Radon Measurement in Water".

The radon concentration in water samples can be determined using the EQF 3300 and the Aqua Kit for Radon-in-water measurement available as an accessory. The Aqua Kit consists of a gas washing bottle and a base with an integrated optical temperature sensor. The sensor cable is connected to the AUX2

accessory socket on the front panel of the radon monitor, into which a defined amount of the water sample is poured.

The Aqua Kit is available as an accessory for determining radon activity concentration. The scope of delivery includes the following components:

- 500 ml gas washing bottle with hose adapters
- Plastic bottle holder with integrated temperature sensor
- Water ingress protection (if not already included with the radon progeny monitor)
- Connecting hoses
- Measurement cycle as a file for uploading to the radon progeny monitor EQF 3300

Note: The monitor is configured for a sample volume of 500 ml. This determines the remaining air volume in the closed air circuit. Both volumes are included in the calculation, so the fill level must always be maintained and only the supplied gas wash bottle may be used.

### 6. 6. 2. Precautions against condensation and water ingress

To avoid condensation in the closed air circuit, the temperature of the water sample should not exceed the ambient temperature of the monitor (allow the sample to cool down before measuring if necessary). The relative humidity in the air circuit then rises to a maximum of 95%. If the relative humidity in the air circuit approaches the dew point ( $RH > 95\%$ ) due to samples that are too warm, a warning message is issued. The measurement must then be aborted immediately and the monitor purged with fresh air. Condensation in the high-voltage measuring chambers can lead to leakage currents that impair the detector signal and thus make a correct measurement impossible. If condensation occurs in the monitor, it must be dried immediately by purging it with dry air for an extended period. Afterwards, a test measurement should be performed to verify that the monitor is functioning properly (assessing the shape of the alpha spectrum). When measuring water samples, it is essential to use the water inlet protection monitor between the gas washing bottle and the monitor's air inlet. This prevents water from entering if, for example, the gas washing bottle connections have been reversed. The float switch immediately interrupts the pump's power supply, preventing water from entering the monitor. Ensure that the stainless-steel vessel is always positioned vertically. Depending on the monitor's positioning, the vessel's position can be adjusted using the accessory adapter. If water is accidentally sucked in, proceed as follows:

- Disconnect the hose connection to the air inlet on the side of the monitor
- Stop the measurement (if it hasn't already stopped automatically).
- Disconnect the hose connection to the gas washing bottle.
- Disconnect the float switch plug connection.
- Remove the vessel from the clamp and unscrew the lid.
- Completely remove water and moisture from the vessel and all hoses.
- Reinstall the water inlet protection. Ensure the rubber seal is properly seated when screwing the lid back on.

### 6. 6. 3. Carrying out the measurement

First, prepare the monitor for measurement by connecting the temperature sensor cable to the "AUX2" socket and making all tube connections:

- Water inlet protection → Monitor air inlet
- Monitor air outlet → Gas washing bottle (immersion tube)
- Gas washing bottle (bottle neck) → Water inlet protection

Note: The tube connections of the water ingress protection monitor are interchangeable. Only the supplied tubes may be used. Other materials (e.g., silicone) are permeable and will cause radon to escape during the measurement.

Before each measurement, the monitor must be purged with fresh air for at least five minutes. To do this, disconnect the tube connections on the gas scrubber and start any measurement cycle. The purging should be carried out for approximately five minutes in a location with very low radon concentrations so that the monitor's internal air circuit is free of radon.

The bottle can now be filled with the specified amount of water (500 ml). Care must be taken to ensure that as little radon as possible escapes during sampling and filling (fill quickly, avoiding large contact surfaces with the ambient air). Then, the cap and dip tube must be tightly screwed on. Ensure that all seals are correctly seated. The bottle is now inserted into the bottle holder, and the "Radon in Water" measurement cycle is started on the monitor. After the measurement cycle is complete, the calculated radon activity concentration is saved and available on the display as the "Radon in Water" measured value.

#### **6. 6. 4. Measuring cycle and used components**

A flow rate of 1 l/min is selected for the measurement to ensure the fastest possible transfer of radon from the water to the air. Concentration equilibrium between water and air is reached after approximately 20 minutes. Since the transfer time constant is slightly longer than the response time of the monitor in radon "fast mode," the actual radon measurement can begin at the 21st minute. From this point on, the temperature is also recorded, as the temperatures of the air and water in the bottle have equalized. The radon measurement lasts 10 minutes, resulting in a total cycle time of 30 minutes.

The signal output of the temperature sensor is connected to the analogous input AIN2. The sensor's supply voltage (+12 V) is supplied via the switching output DOUT2. Since the sensor requires approximately 10 minutes to warm up, the voltage is switched on at the start of the measuring cycle, simultaneously with the pump. Temperature (AIN2) and radon measurements are only active from minute 21 to minute 30. To monitor the relative humidity for condensation from the start of the measuring cycle, an additional I2C component (I2C3) is used, which provides the measured temperature and humidity values for the first 20 minutes. An alarm is set for both components at 95% relative humidity. Exceeding this limit is signalled by default only by the alarm light on the front panel. However, for water measurement, the alarm for the additional humidity measurement (I2C3) is configured so that the measurement is automatically aborted in the event of an alarm.

#### **6. 7. External temperature and humidity sensor**

The ambient temperature and humidity must be measured outside the device, as its power consumption distorts the readings of the internal sensor. The sensor is connected to the 'AUX2' sockets on the device. The required components and measurement cycles are already configured for this sensor when the device is delivered.

## Attachment

### A) DACM32 components

#### A1 - Type of components of DACM32

Type	Name	Description
Analog input	AIN	Connects sensors with analog output signals (0...1 V, 0...2 V, 0...5 V, 0...10 V, 0/4...20 mA).
Status input	DIN	Detects states (e.g., switch contacts), recording the on and off duration and the number of changes.
Comparator-input	CMP	Detects pulse signals that are greater than an adjustable threshold; used in conjunction with a counter input.
Counter input	CNT	Detects a total number of pulses, a pulse rate, or an average pulse rate. Will be used with sensors with a pulse output.
Spectrometer	SPEC	Spectrometer module for recording pulse height spectra.
Universal digital sensor interface	I2C	Connects sensors with a digital interface according to the I2C standard.
Controller	REG	Provides a PID control loop. All available measurement results from existing sensors serve as the setpoint, and a control voltage is output at the controller output.
Switching output	DOUT	Potential-free switching contacts (opto-MOS switch or relay changeover switch)
Frequency generator	PWM	Applies a square-wave signal with variable pulse width to the output.
Calculator	CALC	Calculates complex measurement results from the measured values of the available sensors using functional prototypes.

#### A2 - Overview of the used components in EQF 3320

Name	Alias-Name	Function
AIN1	AUX2-Pin2	Signal at "AUX2" jack Temperature of external temperature/humidity sensor
AIN2	AUX2-Pin5	Signal at "AUX2" jack Rel. humidity of external temperature/humidity sensor
AIN5	Delta-p	Differential pressure, depending on the measuring range AIN5 or I2C3 (only with the "differential pressure sensor" option)
AIN6	Air-flow	Flow measurement and setpoint for flow control
AIN7	Pump current	Measurement of the internal pump current
AIN8	Filter assignment	Measurement of filter occupancy based on the pump voltage
CMP1	AUX1-Pin3	Unused, Signal at „AUX1“ socket, internal connection to CNT1
CNT1	AUX-CMP1	Internally connected to the output of CMP1, unused
DIN 1	AUX2-PIN8	Unused, at socket AUX2
SPEC1	Radon chamber	Connected to the detector signal of the radon measurement chamber, it generates an alpha spectrum and determines the count rates of the individual nuclides. Display: R Po-218, R Po-218/214, R Po-216

SPEC2	Attached progeny	Connected to the filter-detector of the sampling head, generates alpha spectrum and calculates EEC/PAEC for attached fraction
SPEC3	Unattached progeny	Connected to the screen-detector of the sampling head, generates alpha spectrum and calculates EEC/PAEC for unattached fraction
I2C1	AMS5812	Measurement of barometric pressure
I2C2	SHT21	Combined temperature and humidity measurement in the internal air circuit
I2C3	Delta p	Optional Differential pressure sensor for filter control
REG1	Pump controller	Controls the flow via the pump power
DOUT1	AUX2-Pin1 or Signal yellow	Signal to socket "AUX2", either unused or: Power supply for external temperature/humidity sensor Connection of the yellow signal light on the measuring case
DOUT2	AUX2-Pin1 or Signal red	Signal to socket "AUX2", either unused or connection of the red signal light on the measuring case
DOUT6	High voltage	Switches on the high voltage for radon measuring chamber
DOUT7	Pump voltage	Switches on the supply voltage for pump and pump control
CALC1	Radon (fast)	Calculates the radon concentration (Fast-Mode) from Po218-count rate
CALC2	Radon (slow)	Calculates the radon concentration (Slow-Mode) from the sum of the count rates of Po218 and Po214
CALC3	Thoron	Calculates the Thoron concentration from Po216-count rate
CALC4	EQF	Calculates equilibrium factor for radon and its decay products

## B) Connector pin assignment



2 x 4-20mA (M8-PCB-THT-2PC-4P-DCOD-F-ANG-SHLD, Harting, part no. 21420000019)

Pin	Signal	Description
1	AOUT1+	Current Loop 1 Output
2	GND	Common reference potential (-) for AOUT1 and AOUT2
3	AOUT2+	Current Loop 2 Output
4	GND	Common reference potential (-) for AOUT1 and AOUT2

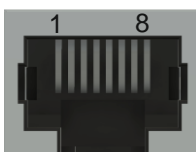

RS485A/RS485B (RJ45 Buchse, 8-pin)

Pin	Signal	Description
4	B/B'	Transceiver terminal 1, V1 voltage (V1 > V0 for binary 1 [OFF] state)

5	A/A'	Transceiver terminal 0, V0 voltage (V0 > V1 for binary 0 [ON] state)
8	GND	Reference potential
1, 2, 3, 6, 7	N.C.	Not used

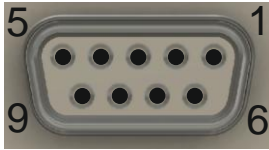

RS232 (SUB-D Buchse, 9-pin)

Pin	Signal	Description
2	TX	Monitor's transmit line (output)
3	RX	Monitor's receive line (input)
5	GND	Reference potential
1, 4, 6, 7, 8, 9	N.C.	Not used

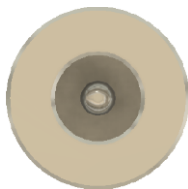

DC (2,5mm jack socket)

Pin	Signal	Description
Inside	20 VDC	Power supply and charging voltage
Housing	GND	Reference potential

### C) Disposal instructions

Batteries and accumulators must not be disposed of in the trash, but must be disposed of at local collection points!

At the end of their service life, the measuring monitors must be disposed of as electronic waste or returned to the manufacturer for proper disposal! If necessary, decontamination must be carried out before disposal.